



Consortium for Computing Sciences in Colleges

*Southeastern Region*

**21<sup>st</sup>  
Annual  
Southeastern  
Conference**

**Student Research  
Contest**

**Extended  
Abstracts**

**November 9 and 10, 2007  
Coastal Carolina University  
Myrtle Beach, South Carolina**

# *Student Research Contest*

## **Extended Abstracts**

1. Hybrid Modeling of Quorum Sensing in *Vibrio Fischeri* Bacteria: Effect of Protein CRP Activity on Luminescence  
*Alexander A. Egariève and Tolulope B. Fatokun*, Fisk University.
2. GPU Implementation of Scientific Computation Applications  
*Chanelle Green*, Spelman College.
3. Voice Over Internet Protocol  
*Ashley Johnson*, Spelman College.
4. XML Representation and Querying of Automated Multi-dimensional Image Analysis Results  
*LaTorria Jones and Katrina Stewart*, Spelman College.
5. Radiological Path Length  
*Chawandia Mack*, Spelman College.
6. An Examination of Martian Topographical Dichotomy using SHARAD Data and Analyzing Martian Gullies for Future Campaigns  
*Stephen L. Strickland*, Wofford College.

# Hybrid Modeling of Quorum Sensing in *Vibrio Fischeri* Bacteria: Effect of Protein CRP Activity on Luminescence

Alexander A. Egarievwe and Tolulope B. Fatokun  
 Fisk University  
 Nashville, Tennessee  
[alexanderegarievwe@yahoo.com](mailto:alexanderegarievwe@yahoo.com)

Dr. Stephan U. Egarievwe, Computer Science

This paper presents the study of the effects of protein CRP activity on the luminescence of *vibrio fischeri* bacteria, using hybrid modeling. *Vibrio fischeri* is a collection of bacteria that exhibits biological luminescence when a certain population level (called a *quorum* of bacteria) is reached. We used Matlab Simulink/Stateflow for our modeling. This work is relevant to providing understanding of how biological cells are integrated and regulated.

A quorum system of the marine bacteria *vibrio fischeri* exist in low densities when it is in form of a free-living organism, and it does not luminescence at such densities. But as a symbionte of some marine fish or squid, the bacteria live at high densities, where it becomes luminescent. The genetic regulatory functions and interactions of biological cells are implemented and controlled by a network of chemical reactions that involve proteins and genes that interact with each other [1]. The concentration of any molecular specie, such as mRNA, protein, protein complex, or small molecule, could be modeled by the following four-component rate equation [2]:

$$dx/dt = \text{synthesis} - \text{decay} \pm \text{transformation} \pm \text{transport}$$

Using this equation, the quorum system can be represented in a nine dimensional state space as described by Alur *et al* [1]. It contain nine variables,  $x_1, x_2, \dots, x_9$ , that describe the concentrations of different molecules as follows:  $x_1$  = mRNA transcribed from  $O_L$ ,  $x_2$  = mRNA transcribed from  $O_R$ ,  $x_3$  = protein LuxR,  $x_4$  = protein LuxI,  $x_5$  = protein LuxA,  $x_6$  = protein LuxB,  $x_7$  = autoinducer inside the bacterium  $A_i$ ,  $x_8$  = LuxR: $A_i$  complex  $Co$ ,  $x_9$  = autoinducer outside the bacterium  $A_{i_{ex}}$ . The differential equations for each mode are of the form  $d(x)/dt = f^i(x)$  where  $i$  is OFF, POS, or NEG. The Simulink/Stateflow model at the top level is shown in Fig. 1.

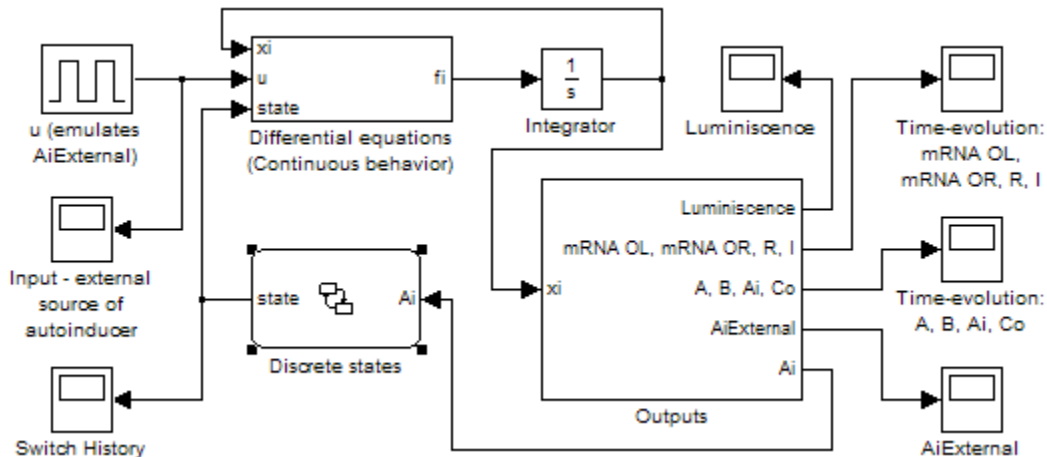

Fig. 1: The Simulink/Stateflow model at the top level.

The discrete variables for the system consist of three distinct states organized into a hierarchy of states as modeled in the stateflow chart in Fig. 2.

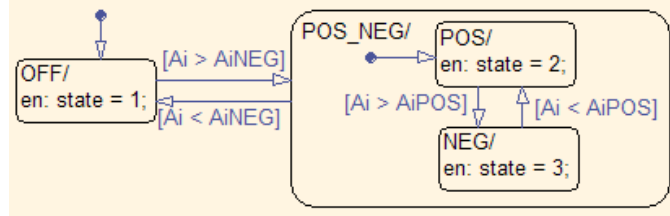

Fig. 2: The stateflow chart of the discrete states.

The results are shown in Figs. 3 and 4. The luminescence was produced as a response of the bacterium to a perturbation in the concentration of an external autoinducer, modeled as pulse generator input in Fig. 1. The results are similar to those of the CHARON simulation by Alur *et al* [1], which also conform to experimental observations.

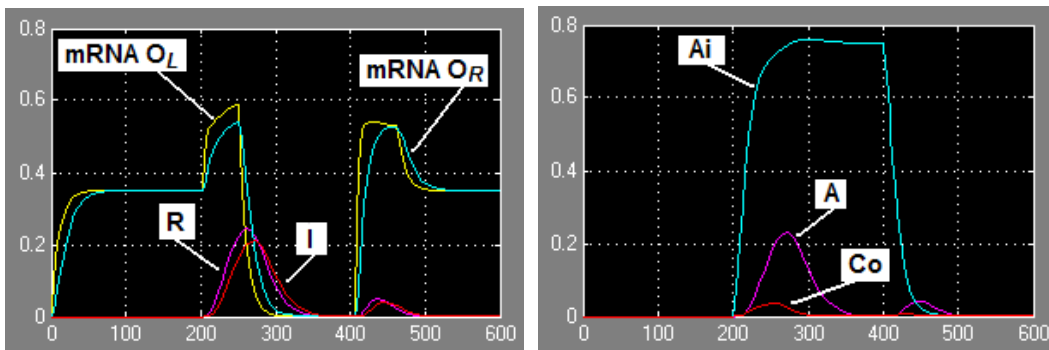
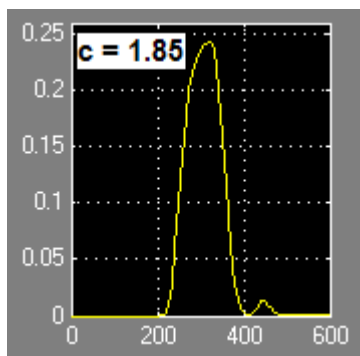
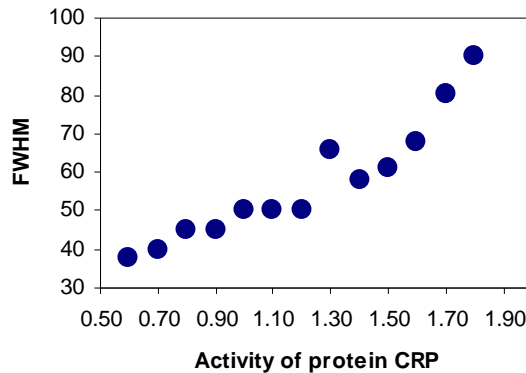

Fig. 3: Time-evolutions of concentrations. Vertical axis is amplitude and horizontal axis is time.



(a) Luminescence at  $c = 1.85$



(b) Dependence of luminescence quality on  $c$ .

Fig. 4: Luminescence.  $c$  = activity of protein CRP. FWHM = full width at half maximum.

We have demonstrated, as shown in Fig. 4b, that the spectral quality of the luminescence is significantly affected by the activity of protein CRP, which depends on its concentration and its affinity to the corresponding binding site.

#### References

1. R. Alur, C. Belta, F. Ivancic, V. Kumar, M. Mintz, G. J. Pappas, H. Rubin, and J. Schug. "Hybrid Modeling and Simulation of Biomolecular Networks." M.D. Di Benedetto, A. Sangiovanni-Vincentelli (Eds.): HSCC 2001, LNCS 2034, pp. 19-32, 2001.
2. G. von Dassow, E. Meir, E. M. Munro, and G. M. Odell. The segment polarity network is a robust development module. *Nature*, 406:188-192, July 2000.

## **Title: GPU Implementation of Scientific Computation Applications**

**Chanelle Green- Spelman College**  
**Diego Rivera-Northeastern University (Mentor)**  
**David Kaeli-Northeastern University (Advisor)**

### **Abstract**

This project demonstrates the use of novel technologies for the purpose of solving Scientific Computation Applications. Graphics Processing Units (GPUs), which usually handle graphics rendering in game consoles and computers, are equipped with a highly parallel and scalable architecture that is perfect for handling intensive computations. NVIDIA GTX8800 cards were used and programmed using an NVIDIA specific middleware known as CUDA. By studying the architecture of the GPU we were able to develop computation intensive programs in such a way that they efficiently made full use of its 128 stream processors. We then put our knowledge to use with a real world application.

The Imaging Division of Massachusetts General Hospital developed an iterative Digital Breast Tomosynthesis (DBT) technique to improve the accuracy and efficiency of Breast Cancer detection. The serial version of the algorithm returned an execution time of 4,157 seconds (70 mins), while the GPU implementation took only 349 seconds (6 mins). We were able to modify the code to print necessary data between iterations to ensure that the algorithm was running efficiently. We also began modifying the algorithm to enable it to run on multiple GPUs. Through GPU implementation, we achieved an increase in both time and cost efficiency.

## **Voice over Internet Protocol**

Ashley Johnson

Spelman College

Atlanta, GA

anjohnson1@gmail.com

Advisor: Ray Gilstrap, NASA Research Engineering Network Group (NREN), NASA

Ames Research Center

Abstract

Voice over Internet Protocol, or VoIP, is a system for placing phone calls over the Internet. Analog phone signals are converted to digital IP packets that are sent over the Internet. VoIP systems are good because they reduce the cost of phone calls by making long distance calls free. NASA can make extensive use of VoIP in areas that may not have access to phone lines, but do have access to the Internet. Calls can be made to astronauts exploring the lunar surface quickly through VoIP.

Asterisk is free software for placing phone calls using IP phones or analog phones and makes use of a computer. It requires a regular telephone, a standard Internet connection, and telephone interface ports that can convert the analog signals to digital, which is cheap and easy to obtain.

In order to set up Asterisk, we installed a Linux server to a computer. After installing Asterisk and its complementary software, we had to configure the software using the many configuration files included in the program. We then tested the configuration using analog and IP phones. Once the phones were able to send and receive calls, they were ready to be used. Researchers in Panama are currently making use of the IP phones and Asterisk. IP phones provide the advantage of being configured miles apart from the server. Access to VoIP technology is crucial because regular cellular and landlines may become unavailable at any time.

Voice over Internet Protocol is proving to be a useful tool as it continues to develop. Although VoIP has problems that come with any technology that works through the Internet, different methods of sending the digital signals through the Internet are being enhanced to further improve the quality of VoIP calls.

## **XML Representation and Querying of Automated Multi-dimensional Image Analysis Results**

LaTorria Jones (ljones26@spelman.edu, Spelman College),  
Katrina Stewart (kstewart@spelman.edu, Spelman College),  
Dr. Badri Roysam (roysam@ecse.rpi.edu, Rensselaer Polytechnic Institute, advisor),  
Prof. James Hale ([jhale@spelman.edu](mailto:jhale@spelman.edu), Spelman College, advisor)

Farsight, by definition, is a toolbox of computational methods that enables automated associative analysis of 3D multi-parameter images of brain tissue. It provides a systematic and methodical “divide and conquer” strategy for making quantitative measurements of complex tissue level image data. In addition, Farsight facilitates automated nuclear identification, cell classification, and quantification of relationships among tissue components. The Farsight output is a detailed eXtensible Markup Language (XML) file containing measurements of complex tissue level image data. Our quantitative research introduces the concept of querying the Farsight XML file containing these measurements of 3D multi-parameter images.

The goal of our research is to create an interactive high-level abstraction for naïve XML and XQuery users by developing an application that at high-level will use natural language to formulate lower-level queries. This will allow users to make use of their natural language (i.e. English), to develop sophisticated queries with out prior knowledge of query syntax. The system should eliminate the need for expert users, knowledgeable in any of the following languages: XML, XQuery, XPath, XSL transformation (XSLT), HTML, and Scalable Vector Graphics (SVG). Our application is expected to effectively receive the natural language queries, construct the lower-level queries using XPath and XSL syntax and generate results of the query in the form of a table and/or graph. The format of the output will be depended on user preference.

Currently, our research is in implementation phase. A website has been created as an initial means of interfacing between the user and the XML query software. The site allows the user to browse for an XML file, upload the file, and submit their natural language query. XPath and XSLT are used to retrieve information from the provided XML document. XSLT generates the results in HTML. If the user has specified tabular and graphical representation of the results, our software will translate the HTML results into SVG graphics (i.e. pie chart, histogram, line graph).The SVG graphs will directly relate to generated data tables to allow for interactivity between the user and the generated results. Presently, we can generate tabular and graphical representations of a specific query, hard coded into our software.

The future goals of our research include, optimizing the query process, transitioning from natural language to XPath, XSTL, and XQuery syntax, increasing user interactivity, and implementing a database for storage and retrieval of queries. Our main focus is to

implement a program for the transition from natural language to XQuery syntax. Natural language queries will be translated from HTML to XQuery syntax using XSLT. The software will search through the XML document for keywords pertaining to the users query. We anticipate that keyword or full text searching will optimize the querying process. In the future we will increase interactivity by directly relating the SVG graphs to HTML tabular results. For example, if the mouse hovers over data in the table, its location will be highlighted in the graph. Finally, we strive to incorporate a database that will allow users to have user profiles, conduct querying sessions and retrieve queries and result for a given session.



**Title: Radiological Path Length**  
**Chawandia Mack – Spelman College**  
**Burak Erem – Northeastern University (Mentor)**  
**Professor David Kaeli – Northeastern University (Advisor)**

**Abstract**

In conjunction with Massachusetts General Hospital (MGH), this project demonstrates the uses of a programming environment called Scientific Computing and Imaging (SciRun) as a bases to aid doctors in treating cancer patience's more effectively. The problem that lies with treating cancer patience's now is the effect of the treatment on the human cells. (Healthy Cell tissues vs. Cancerous Cell tissues) How can doctors effective treat the cancerous cell tissues in the body with out killing off healthy cells?

SciRun is a problem solving environment that allows interactive construction, debugging, and the steering of large scale scientific computations. Because of SciRun user friendly environment, we used SciRun to create tools that would be able to keep track of tumors (cancerous cell tissues) over time throughout the human body. This in return would provide doctors with a path of points that represent a specific time where the tumor would lie in the body. In creating these tools, we are one step closer to locating every possible location a tumor can have at a given space in time in the human body. The experimentation and results of this study will be further expounded.

## **An Examination of Martian Topographical Dichotomy using SHARAD Data and Analyzing Martian Gullies for Future Campaigns**

Stephen L Strickland  
Wofford College  
Spartanburg, SC  
[stricklandsl@wofford.edu](mailto:stricklandsl@wofford.edu)  
Dr. Angela Shiflet

Research was conducted at the Jet Propulsion Laboratory in Pasadena, CA under the guidance of Dr. Suzanne Smrekar in a summer internship funded by the South Carolina Space Grant Consortium. Computation analysis with innovative programs facilitated interpretation of Martian topographical data.

The Martian dichotomy boundary divides the Southern highlands from the Northern lowlands and is believed to have extended through gravitational relaxation. Topographic shelves and the disappearance of topographic “knobs” parallel to observed normal faults provide evidence of buried extensional faults. SHARAD ground penetrating radar data is able to observe subsurface features including faults. A program was written to map the SHARAD orbits over the Ismenius region, and the radargrams were analyzed with topographical data, MOLA data, as well as clutter simulations and examinations of RBG spectra in SHARAD data to judge possible remnant faulting and subsurface discontinuities. Potential subsurface faults are being examined. The next step is to simulate the radar backscatter due to topography to distinguish surface “clutter” from subsurface features.

Many hypotheses have been suggested to explain Martian gully activity including the presence of leaking subterranean aquifers. To date, relatively few gully regions have been investigated using SHARAD data. Because of SHARAD’s sensitivity to certain conditions, the SHARAD Team has produced a map detailing the probability of high quality SHARAD data from any given region. Code was written to map the gully locations onto this map, and an analysis of the best targets for future campaigns is underway.